

name	PIXL 7 LEAF MAINS DIMM	
ref	417337	PIXL 7 3000K 50° TEXTURED WHITE
	417316	PIXL 7 3000K 50° TEXTURED BLACK
	417347	PIXL 7 2700K 50° TEXTURED WHITE
	417326	PIXL 7 2700K 50° TEXTURED BLACK
	417357	PIXL 7 3000K 80° TEXTURED WHITE
	417336	PIXL 7 3000K 80° TEXTURED BLACK
	417367	PIXL 7 2700K 80° TEXTURED WHITE
417346	PIXL 7 2700K 80° TEXTURED BLACK	
safe distance to object	☞ - 0,1m - ☚	
lamp / (lum.flux) / (colortemp)	LEDARRAY L278	1982lm 2700K
	LEDARRAY L278	2081lm 3000K
fitting	None	
watt	13,94W	
voltage or current	220-240V AC	
symbol		
gear	Converter incorporated	
ip/class	IP20	
application	Interior - Ceiling Mounted	
orientability	Not Orientable	
dimmiability	Dimmable RC (via dimlist type AE)	
weight		
beamangle	50°- 80° (UGR <19)	
CRI	>90	
SDCM	3	
Ta max	40°C	

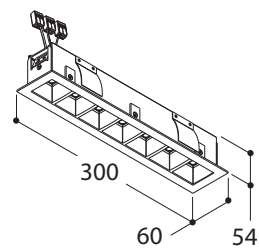

① Make prescribed hole in the ceiling

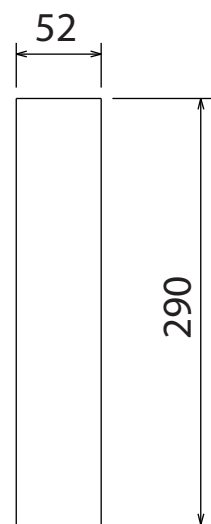

Min. ceiling thickness = 10mm  
Max. ceiling thickness = 25mm  
Min. installation depth = 60mm

② Make electrical connection

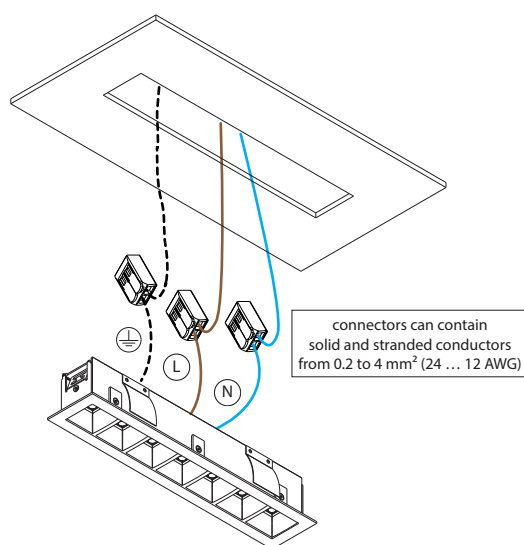

Do not cover top of luminaire with isolation (Ta max 40°C)

③ Mount the fixture in the ceiling

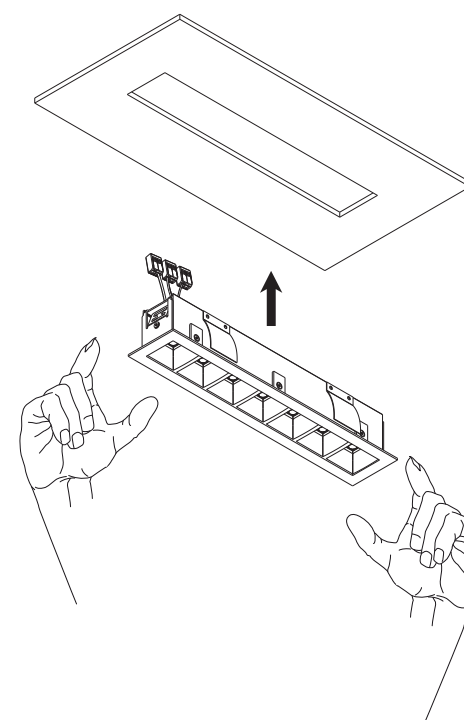

④ Turn on the mains power supply

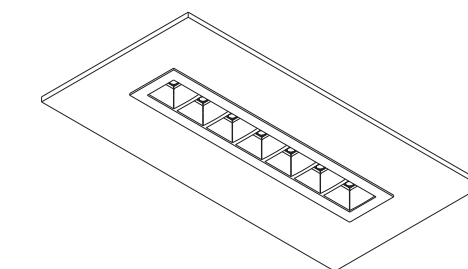

Replaceable light source by a professional

Installation with FRAME for PLASTER (417299):

① Make prescribed hole in the ceiling

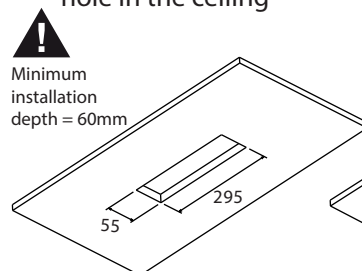

② Mount the plasterkit

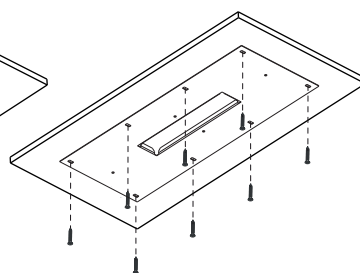

③ Add plaster to kit and screws Sand and paint afterwards

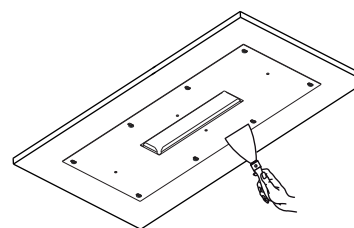

④ Follow step 2 from regular installation for further finishing

Installation with FRAME + BOX for PLASTER (417297):

① Mount conbox in hole using screws / concrete

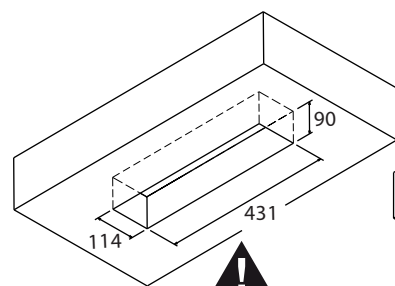

② Mount the plasterkit

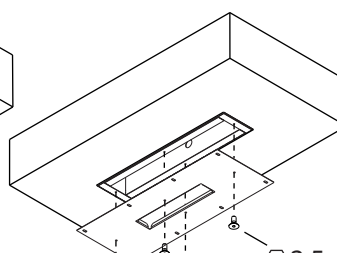

③ Add plaster to kit and screws Sand and paint afterwards

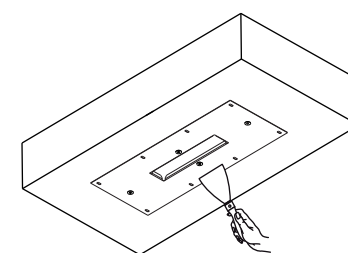

④ Follow step 2 from regular installation for further finishing

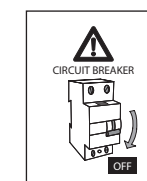

ALWAYS DISCONNECT MAINS POWER SUPPLY FROM CONVERTER BEFORE SWITCHING "ON" LED LUMINAIRES TO PREVENT HOT PLUGGING ISSUES

INSTALLATIE- EN ONDERHOUDSRICHTLIJNEN m.b.t. FABRIEKSGARANTIE.  
1. DE VERBINDINGEN EN HET UITTESTEN VAN DEZE TOESTELLEN DIENEN ALTIJD TE GEBEUREN DOOR EEN ERKEND ELECTRO-INSTALLATEUR.  
2. DEZE VERLICHTINGSTOESTELLEN MOETEN GEïNSTALLEERD, VERBODEN EN GETEST WORDEN VOLGENS DE NATIONAAL GELDENDE REGLEMENTEN OP DE ELECTRISCHE INSTALLATIES (BELGIE: A.R.E.I., DUITSLAND: DIN VDE 0100 TEIL 559 A2, ...; DEZE OPSOMMING IS LOUWER INFORMATIEF)  
3. DE TECHNISCHE BIJSLUITER MOET GEZIEN WORDEN ALS ONDERDEEL VAN DE ALGEMENE VERKOOPVOORWAARDEN VAN TAL N.V.  
4. DE ELECTRO-INSTALLATEUR IS VERANTWOORDELIJK VOOR HET GEBRUIKEN VAN VOORSCHAKELAPPARATUUR DIE VOLDOET AAN DE GELDENDE CE EN EMC NORMEN.  
5. VERVANG DE LAMP (-EN) ALTIJD MET DE GROOTSTE ZORG, ZE IS (ZIJN) UITERST BREEKBAAR.  
6. OPGEPAST: PLAATS NOOIT DE LAMP MET BLOTE HANDEN, GEBRUIK ALTIJD EEN DOEK!

INSTRUCTIONS D'INSTALLATION ET D'ENTRETIEN A RESPECTER VIS-A-VIS DE LA GARANTIE.  
1. LE PLACEMENT, LE RACCORDEMENT ET L'ESSAI DE CET APPAREIL DOIVENT TOUJOURS ETRE EFFECTUES PAR UN INSTALLATEUR ELECTRICIEN AGREÉ.  
2. LES LUMINAIRES DOIVENT ETRE INSTALLEZ, BRANCHES ET TESTES SUIVANT LE REGLEMENT NATIONAL SUR LES INSTALLATIONS ELECTRIQUES EN VIGUEUR. (BELGIQUE: A.R.E.I., ALLEMAGNE: DIN VDE 0100 TEIL 559 A2, ...; CETTE ENUMERATION EST INDICATIVE)  
3. CE MANUEL D'INSTALLATION TECHNIQUE REPRESENTE UNE PARTIE DES CONDITIONS GENERALES DE VENTE DE TAL N.V.  
4. L'ELECTRO-INSTALLATEUR EST RESPONSABLE POUR L'USAGE DE BALLASTS, TRANSFO...CONFORMES AUX NORMES CE ET EMC EN VIGUEUR.  
5. REMPLACEZ TOUJOURS L'AMPOULE (LES AMPOULES) AVEC PRUDENCE; ELLE(-S) EST (SONT) TRES FRAGILE (-S).  
6. ATTENTION: NE JAMAIS REMPLACER L'AMPOULE AUX MAINS NUES, UTILISEZ TOUJOURS UN CHIFFON!

INSTALLATION AND MAINTENANCE INSTRUCTIONS IN VIEW OF THE MANUFACTURER'S GUARANTEE.  
1. THE CONNECTION AND TESTING OF THE DEVICES SHOULD ALWAYS BE PERFORMED BY A RECOGNIZED ELECTRICIAN.  
2. THESE LIGHTING DEVICES NEED TO BE INSTALLED, CONNECTED AND TESTED FOLLOWING THE OFFICIAL NATIONAL INSTRUCTION GUIDE FOR ELECTRICAL INSTALLATIONS (BELGIUM: A.R.E.I., GERMANY: DIN VDE 0100 TEIL 559 A2, ...; THIS ENUMERATION IS JUST AN INDICATION)  
3. THIS TECHNICAL ENCLOSURE NEEDS TO BE ADDED TO THE GENERAL SALES CONDITION OF THE TAL N.V.  
4. THE ELECTRO TECHNICIAN IS RESPONSABLE TO USE BALLASTS, TRANSFORMERS...WHICH MEET THE VALID CE AND EMC RULES.  
5. ALWAYS REPLACE THE LAMP (-S) WITH UTMOST CAUTIOUSNESS, THE LAMP (-S) IS (ARE) VERY FRAGILE.  
6. ATTENTION: NEVER REPLACE THE LAMP WITH BARE HANDS, ALWAYS USE A CLOTH!

MONTAGE- UN UNTERHALT INSTRUCTIONEN ZU BEACHTEN MIT BEZUG AUF DER GARANTIE.  
1. DIE MONTAGE, DER ANSCHLUSS UND DAS AUSTESTEN DER LEUCHTEN SOLL IMMER VON EINEM ZUSTANDIGEN ELECTRO-INSTALLATEUR AUSGEFÜHRT WERDEN.  
2. DIESE LEUCHTEN MÜSSEN INSTALLIERT, ANGESCHLOSSEN UND GETESTET WERDEN NACH DER ALLGEMEINEN NAZIONALEN REGLEMENTATION ÜBER DIE ELEKTRISCHE INSTALLATIONEN (BELGIEN: A.R.E.I., DEUTSCHLAND: DIN VDE 0100 TEIL 559 A2, ...; DIESE AUFSTELLUNG GESCHICHT DURCH EXEMPLATIVEN TITEL UND KANN NICHT ALS LIMITATIV ODER EXHAUTIV BETRACHTET WERDEN).  
3. DIESE TECHNISCHE GEBRAUCHSANWEISUNG GEHÖRT ZU DEN ALLGEMEINEN VERKAUFSBEDINGUNGEN VON TAL N.V.  
4. DER ELECTRO-INSTALLATEUR IST VERANTWORTLICH FÜR DAS VERWENDEN VON CE UND EMC GEPRÜFTE VORSCHALTGERÄTE.  
5. DIE LAMPE(-N) SOLL(-EN) IMMER SERH VORSICHTIG ERSATZT WERDEN.  
6. VORSICHT: MAN DARF NIE DIE LAMPE MIT DEN NACKTEN HANDEN BERÜHREN, MAN SOLL IMMER EINEN TUCH BENUTZEN!